

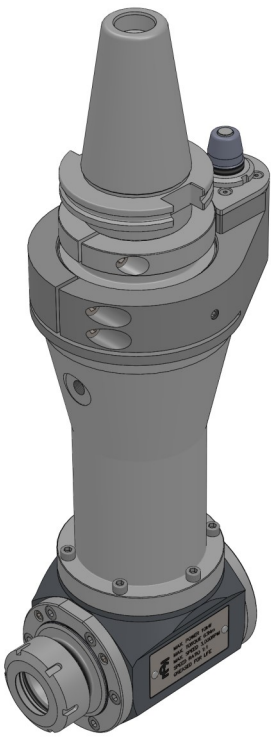





RAD225 - 375 Extended 90° Angle Head

225



Technical Data

	ER40 — 30mm / M22	
	Max. 3,000rpm Speed ratio 1 : 1	
	Max. @ 3,000rpm	10kW
	Max. @ 100rpm	63Nm
	(Without tools)	26.2kg
	Input Opposite to Output	

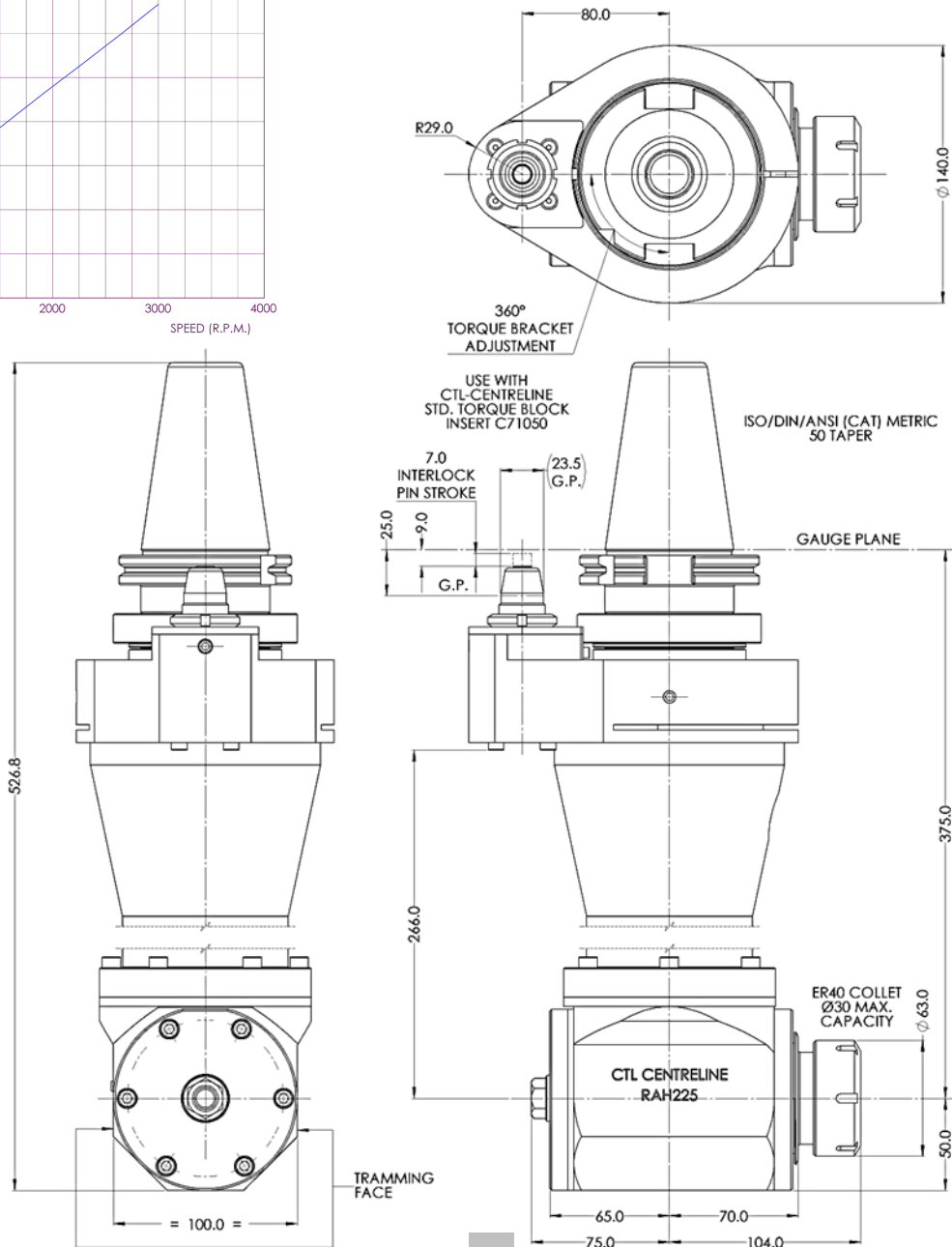
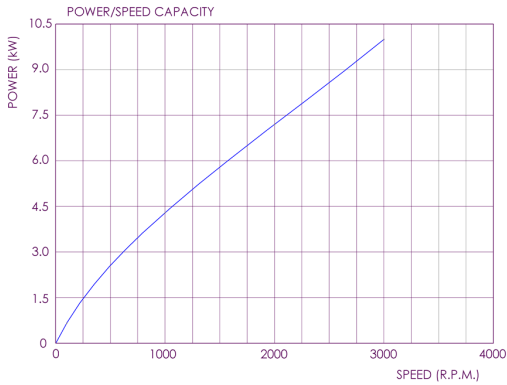

225 Series 90° Angle Heads

225

- Standard Length or Extended length
- ER40 (30mm Cap.) Collet Chuck or Modular ISO30 Output
- High Pressure Through Coolant option with Outlet via Body or Spindle
- Single or Double Output
- Location Pin Centres — 80mm, 100mm & 110mm
- 360° adjustability
- Special output options available
- Maintenance free sealed design. Grease lubricated

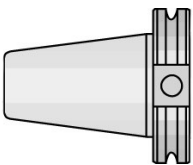

Available drive Tapers:

BT50

CAT50 (DIN / ANSI / SK)

HSK 80A, HSK 100A

Capto C8

KM 80

(40 ISO tapers and other options available on request)

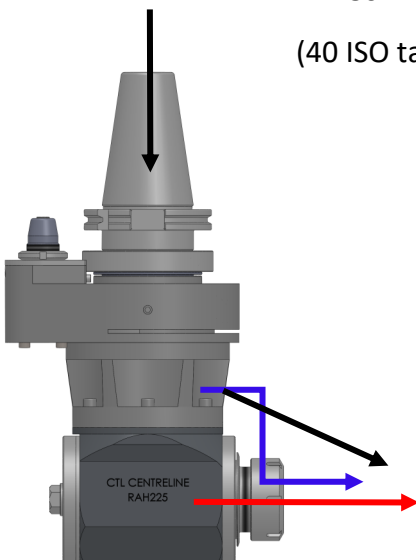

Internal Coolant Options:

A - In through Shank - Out through Body

B - In through Shank - Out through Spindle / Tool

C - In through Shank - out via Special Through Coolant Locknut